



# RADIANT HEAT INSTALLATIONS

With radiant heat, the heat source is directly beneath the flooring, so the flooring may dry out faster than a similar floor in a home with a conventional heating system. Wood flooring can be installed over radiant heat as long as you understand radiant heat and how it can impact wood flooring, what precautions to take, and what type of wood flooring to use.

Types of wood flooring that are best suited-for radiant heat subfloor are products that possess improved dimensional stability such as:

- Engineered wood flooring is more dimensionally stable than solid wood flooring.
- Certain species are known for their inherent dimensional stability such as North American oak, American cherry, American walnut and others. Denser species such as maple and Brazilian cherry are less stable.
- Quartersawn and rift-sawn wood flooring is more dimensionally stable in width than plain sawn wood flooring.
- Narrow boards are more dimensionally stable than wide boards.

## GENERAL RADIANT HEAT INSTALLATION GUIDELINES

- To minimize the effect that rapid changes in temperature will have on the moisture content of the wood floor, NWFA recommends that an outside thermostat be installed. If one is not present, suggest to your customer that this should be considered. Unlike conventional heating systems, which switch on as needed, radiant systems work most effectively and with less trauma to the wood floor if the heating process is gradual, based on small incremental increases in relation to the outside temperature.
- Subfloors should have proper moisture tests according to the moisture testing procedures
- The essential requirement in proper applications of wood flooring over radiant heated systems is to avoid penetration of the heating element. Radiant-heated subfloor systems can be concrete, wood or a combination of both. The type of subfloor determines subfloor preparation.
- If the subfloor is concrete and it has cured, turn the heat on, regardless of season, and leave it on for at least 5-6 days to drive out residual moisture before installation of the wood flooring. Some installation systems, particularly glue-down applications, require the heat to be reduced or even turned off before installation of the flooring begins, so the adhesive does not cure excessively.
- With water-heated radiant-heat systems, a pressure test must be performed and documented by a qualified plumber or the system installer prior to beginning the installation of the wood flooring.
- If flooring materials that conduct heat at different rates are on the same circuit or heating zone, check with the HVAC mechanical engineer before proceeding.



- Radiant heat is dry heat. A humidification system may be necessary to maintain wood flooring in its comfort zone.

The following installation and subfloor systems can be used successfully over radiant heat:

- 1. Glue-down, engineered or solid parquet
- 2. Floating engineered
- 3. Direct-nail, solid wood or engineered wood flooring to wood subfloor
- 4. Solid T&G floor direct-nail to sleepers
- 5. Single layer of plywood on sleepers
- 6. Double plywood floating subfloor
- 7. Loose-lay single layer of  $\frac{3}{4}$ " plywood cut in 16" planks staggered with  $\frac{1}{2}$ " gap between laid perpendicular to wood direction

## GLUE-DOWN, ENGINEERED OR SOLID PARQUET

**NOTE: Follow manufacturer's installation instructions.**

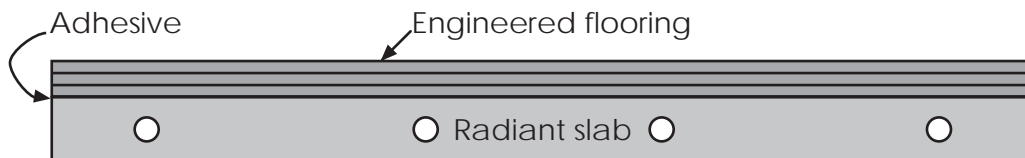

Install over approved subfloor.  
Engineered Flooring Installation.

- Use an adhesive approved by the manufacturer.
- The heating system has to be turned off before installation.
- The maximum allowable subfloor surface temperature is 85° F (29.44° C).
- Expect some heating season shrinkage.

## DIRECT NAIL, SOLID WOOD OR ENGINEERED TO WOOD SUBFLOOR

NOTE: Follow manufacturer's installation instructions.

- Install over approved subfloor.
- Always check for subfloor moisture.
- Solid wood must be properly acclimated to normal living conditions.
- All other installation procedures as a normal Engineered Flooring installation or solid strip and plank Installation.
- Be sure fasteners are not so long as to penetrate heating elements.
- Maximum subfloor surface temperature-85° F (29.44° C).

### **Direct Nail to Subfloor Over Joists**

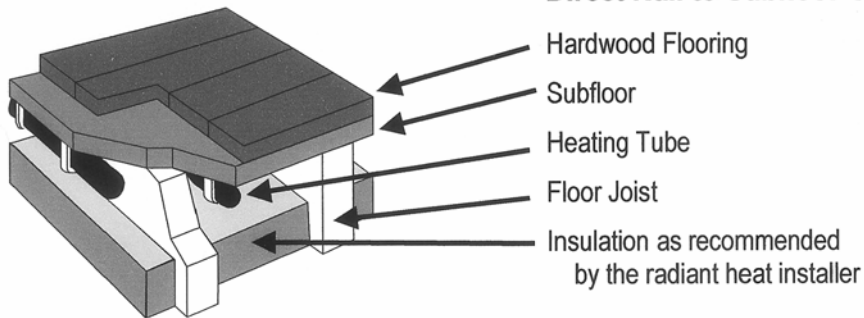

### **Direct Nail to Subfloor Over Sleepers**

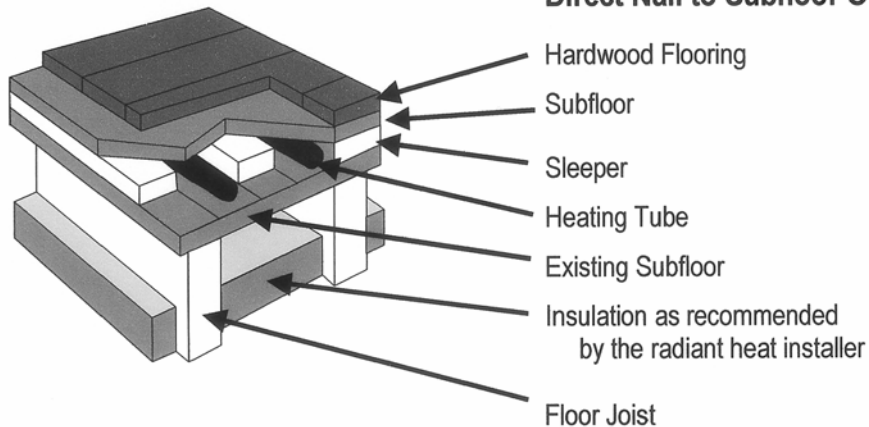

## SOLID T & G FLOOR DIRECT NAIL TO SLEEPERS

NOTE: Follow manufacturer's installation instructions.

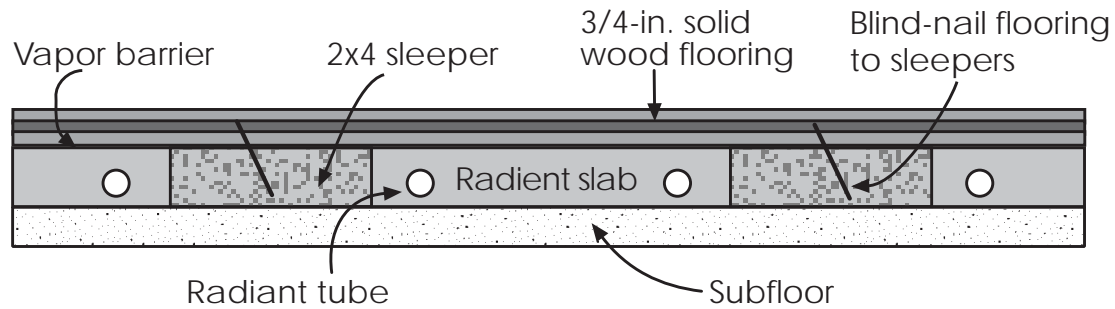

- The use of solid wood flooring 4 inches and wider is not recommended over sleepers.
- Solid wood must be properly acclimated.
- Cannot use shorts.
- Maximum subfloor surface temperature - 85° F (29.44° C)

## SINGLE LAYER OF PLYWOOD ON SLEEPERS

NOTE: Follow manufacturer's installation instructions.

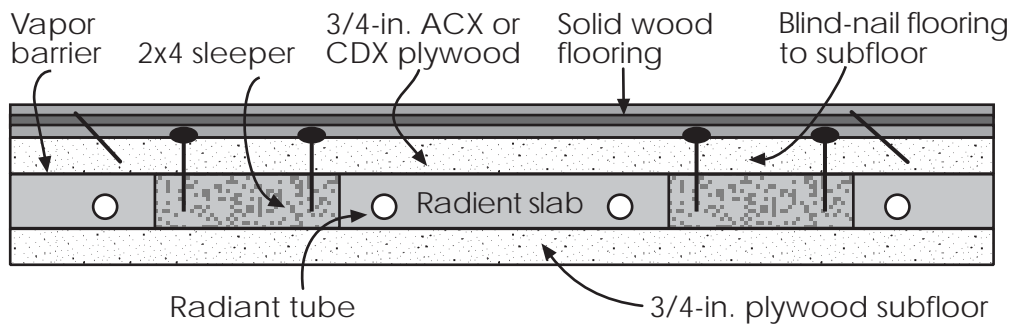

- Solid wood must be properly acclimated.
- Maximum subfloor surface temperature-85° F (29.44° C)

## DOUBLE PLYWOOD

NOTE: Follow manufacturer's installation instructions.

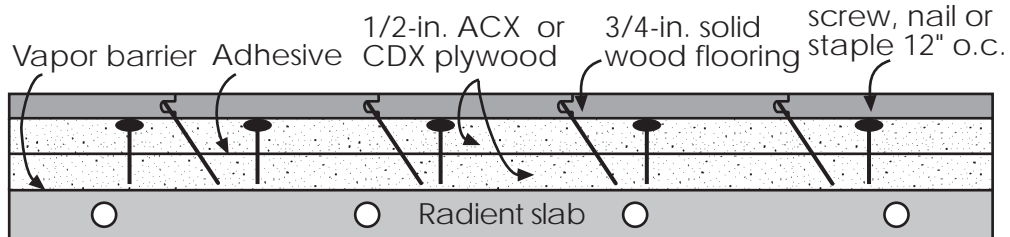

- Solid wood must be properly acclimated.
- Maximum subfloor surface temperature - 85° F (29.44° C)

## FLOATING ENGINEERED

NOTE: Follow manufacturer's installation instructions.

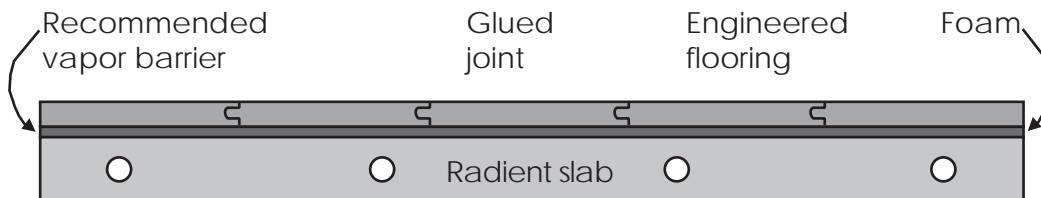

- Install over approved subfloor.
- A 6 mil or better polyethylene vapor retarder should be installed over concrete subfloors. In some cases, this may be part of the flooring underlayment.
- A foam or resilient underlayment recommended by the flooring manufacturer must be installed prior to application of the wood flooring.
- Use an adhesive approved by the manufacturer for side and/or end joints.
- Maximum subfloor surface temperature-85° F (29.44° C).